



ULTRASONIC LEVEL METERS

Compact Transmitters: STD, SBD 300 series
Two part Systems: SID and SM 300 series

**FOR
SOLIDS**

COMPACT TRANSMITTERS

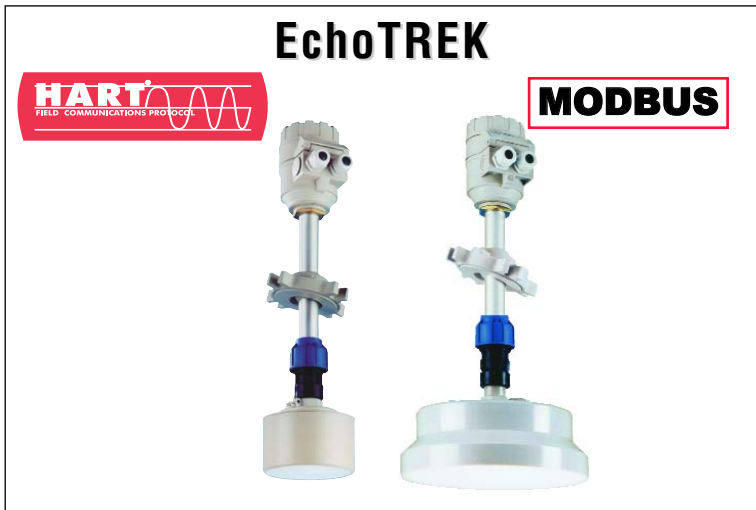

➤ **Excellent sensor focusing:
5° total beam angle**

➤ **Highly efficient
foam-faced sensors**

➤ **Built-in temperature
compensation
on full scale**

TWO-PART MEASURING SYSTEM



➤ **Built-in secondary
lightning protection**

➤ **Built-in aimer for
EchoTREK**

➤ **Two decades of
experience with
ultrasonics**

KNOW-HOW IN ULTRASONICS

Nivelco's two decades of experience in ultrasonic level metering is an asset we gladly share with our customers. A specialised team works continuously to update and improve Nivelco products with new innovations and the experience gained from tens of thousands of applications worldwide.

The state-of-the-art, narrow-beam angle sensor and the QUEST+ (Qualified Echo Suppressing Technique) featuring advanced, process adaptive digital signal processing provide the basis for the solution of the most demanding applications in the process control world.

FIELDS OF APPLICATION

Ultrasonic Level Meters offer excellent tools for level and volume measurements in bins and silos containing powders or bulk solids.

Level measurement technology based on the non-contacting ultrasonic principle is especially suited for applications where, for any reason, no physical contact can be established with the surface of the material to be measured.

Applying non-contact ultrasonic principle for level measurements has proven reliable where other, high maintenance level detectors such as cable probes, paddle wheels and plumb bombs are not preferred because of negative field experience. No other technology in the field of continuous level sensing offers as little maintenance requirement as ultrasonic.

PRINCIPLE OF OPERATION

Ultrasonic level metering technology is based on the principle of measuring the time required for the ultrasonic pulses to make a round trip from the sensor to the surface of the free flowing solid and back. The sensor installed above the surface to be measured emits an ultrasonic pulse train and receives the echoes reflected. The received signals are processed by selecting the echo reflected by the surface and calculating the distance to the surface from the time of flight. This also constitutes for calculation of other process values.

The Measuring System

Compact Transmitters

Standalone devices with sensor and transmitter in one unit



Two-part System

Separate sensor and transmitter control unit



MEASURING RANGE

The measuring range, or more exactly the distance the ultrasonic unit can measure depends on the ambient conditions (e.g. closed silo or open vessel). Proper care must be taken in open-air applications, where intensive air movements (i.e. wind or storm) may "blow away" the ultrasound at high distances, thereby reducing effective range.

There are a few other phenomena such as particle size, specific gravity of the medium, height-to-diameter ratio of silo and dusting in particular that can reduce (with heavily dusting powders as much as 50%) the range of the measuring unit.

TRANSDUCERS

Transducers, designed for heavy-duty use, come in a robust housing with a special closed cell foam face that is immune to vapours and condensation.

Aiming which is usually required for free-flowing solid applications can be performed by the optional, robust paint coated aluminium aiming device integrated in the Compact Transmitters.

TEMPERATURE

All Nivelco ultrasonic devices have built in temperature compensation providing for accurate metering over the full measuring range.

PRESSURE

Because of the physical characteristics of ultrasound, ultrasonic measurement is limited in vacuum and high pressure applications.

SONIC CONE

Most of Nivelco's transducers have a **5°-7° total beam angle** at -3 dB, ensuring a reliable measurement in narrow silos with uneven side walls as well as in process bins with various protruding objects. Furthermore, as a result of the narrow beam angle, the emitted ultrasonic signal ensures outstanding focusing and good penetration through dust.

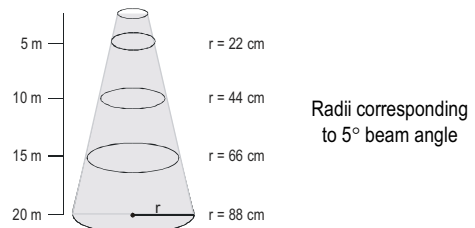

SELECTION

We offer level measurement solutions including standalone devices and two-part systems with different working frequencies.

Since the main selection aspects mentioned above (see "Measuring Range") form only a part of the selection and application know-how, please contact **your local NIVELCO distributor** to assist you in selecting your optimal ultrasonic system.

COMPACT TRANSMITTERS

Standalone devices with a transducer and a transmitter in one unit

EchoTREK - THE NEXT GENERATION

Nivelco's next generation of SMART compact ultrasonic level transmitters integrate SenSonic transducers (providing an excellent narrow beam angle and high efficiency for superb signal reproduction) as well as the QUEST+ software using advanced, process adaptive digital signal processing.

The EchoTREK is an ultrasonic level transmitter with capabilities of measuring the level of almost any powder or bulk solid, even in challenging applications such as dusting of powders caused by pneumatic filling and uneven surface of material, etc. It is an ideal tool for those, preferring uncompromising measurement performance, but not requiring a remotely mounted, separate control unit.

All the above is provided in a unique compact package that is simple to install and putting into service, providing a cost-effective solution for single as well as multi-vessel applications.

The EchoTREK standard model incorporates current output and a fully programmable power relay for various alarm and control functions. As a standard its software features 32 point linearisation, over 10 pre-programmed tank shapes for calculation of volume/weight as well as the ability to suppress the interference of an echo from a fixed object (such as ladder, bracing etc.)

EchoTREK

STD-300
SBD-300

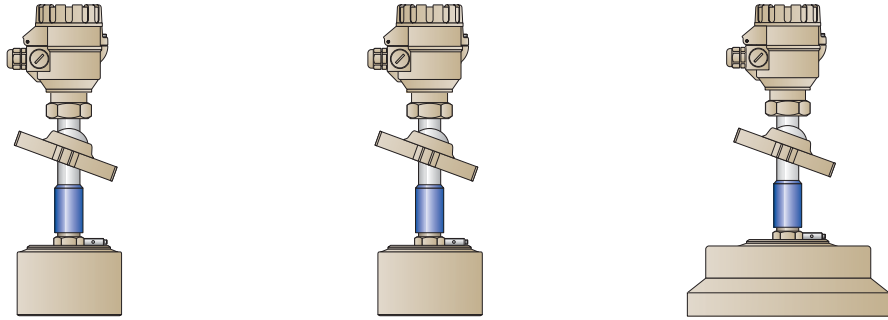

Type	STD/SBD-34	STD/SBD-33	STD/SBD-31
Suggested applications	Small silos, hoppers, conveyor-belt monitoring up to 8 m Short range*	Short range for powders and heavy dusting granules up to 25 m Medium range for non-dusting granules*	Medium range for powders and heavy dusting granules up to 50 m Long range for non-dusting granules*
Mounting (min. flange)	DN150 / ANSI 6"	DN150 / ANSI 6"	DN300 / ANSI 12"
Frequency	30 kHz	30 kHz	15 kHz
Dust penetration	xxx	xxx	xxxx

*With respect to the measuring range of a given application, please contact your local Nivelco distributor
xxx= good; xxxx= excellent

On site programming/display

The SAP-100 (plug-in) programming and display module used with STD-300 units or incorporated in the SBD-300 models enables the so-called menu driven "QUICKSET" or full parameter programming with access to all features of the smart device.

In the measurement mode the selected measurement value will be indicated on the 6 - digit display.

A unique bargraph provides prompt visual information on the (echo) signal strength or measurement value.

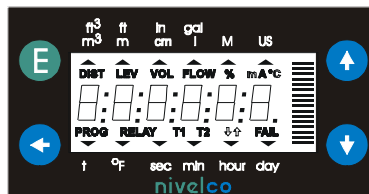

SAP-100 module

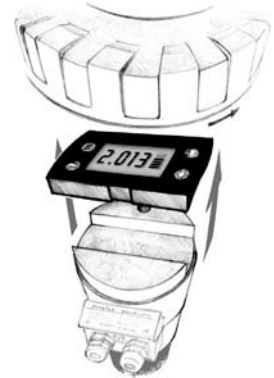

Remote programming/digital communication

Digital communication provides for remote programming of and acquiring information from the field devices.

HART

EchoTREK with HART and the configuration software EVView (running under Windows) enables remote programming of up to 15 field devices and viewing of the primary measurement values on a PC.

RS485 with MODBUS protocol (under development)

For remote programming of up to 30 field devices and monitoring, data acquisition or process control.

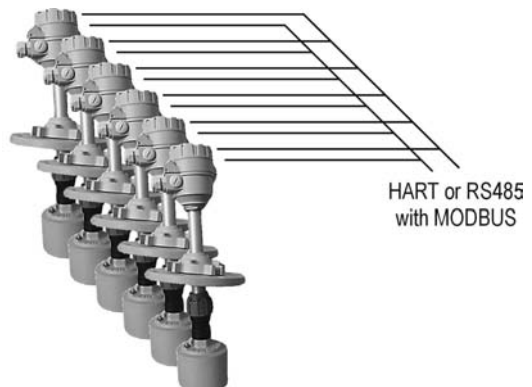

Two-Part Measurement Systems

The **Two-Part Measurement System** consists of **SenSonar Sensor(s)** and a **NIVOSONAR Control Unit** for remote signal processing (of the special signal provided by the sensor), indication and the output of measurement values.

This powerful measuring system is capable of measuring the level of almost any free flowing or bulk solid, even under the most difficult conditions such as heavily dusting powders caused by pneumatic filling and repose formation of the material, etc.

SenSonar Sensors

These sensors, using Nivelco's latest SenSonic transducer technology, create a burst of sound with excellent narrow beam angle and high efficiency for superb signal reproduction.

SenSonar

SID-300

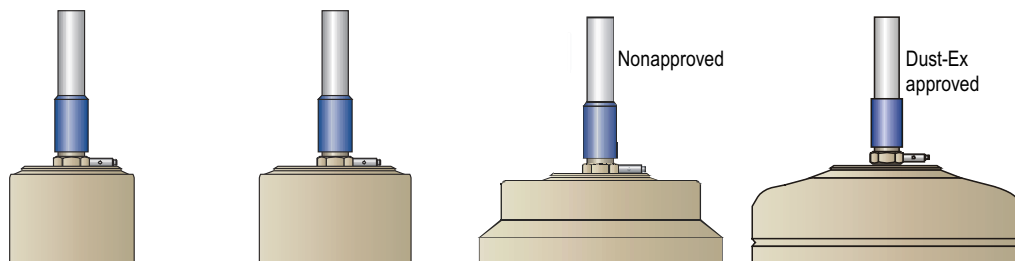

Type	SID-340	SID-330	SID-310	SID-310-3
Suggested applications*	Small silos, hoppers, conveyor-belt monitoring Short range unit up to 15 m	Short/medium range for powders and heavy dusting granules Medium range up to 30 m for non-dusting granules	Medium range for powders and heavy dusting granules Long range up to 60 m for non-dusting granules	Long range for powders and heavy dusting granules Long range up to 70 m for non-dusting granules
Mounting	1" BSP	1" BSP	1" BSP	1" BSP
Frequency	40 kHz	30 kHz	15 kHz	15 kHz
Dust penetration	xx	xxx	xxxx	xxxxx

*With respect to the measuring range of a given application, please contact your local Nivelco distributor

x= weak; xxxxx= excellent

NIVOSONAR Control Units

A wide range of control units located remotely from the sensor(s), with different features and mechanical designs are available. Nivelco's QUEST+ software provides for advanced, process adaptive digital signal processing.

The user/operator can conveniently view measurement values on the display and set up the control unit by using the full keypad.

NIVOSONAR

SM-300



Type	SMM/SMZ-300	SMW/SMC/SMD/SMH-300
Mounting	Panel mounting	Wall mounting
Ingress	IP40	IP54 or IP65
Measurement channel(s)	1	Up to 2
Current output	1	Up to 2
Relays	Up to 3	Up to 8
RS485	Optional	Optional
RS232	Standard	Standard
Average level calculation	Not applicable	Standard
Supports the SLM scanner	Yes	Not applicable

Features (common to both Compact and Two-Part System except those with remark in parenthesis)

MEASUREMENT AND OUTPUT

In the concept of the ultrasonic level measurement, distance (between the sensor face and surface of the material) may be considered as the primary measurement value which constitutes the basis of all other values calculated, such as level, volume*, weight*, level or volume as a percentage (differential level or average level for the two-part system only). The measured and calculated values will be transmitted and displayed (exception: STD-3□□ without display).

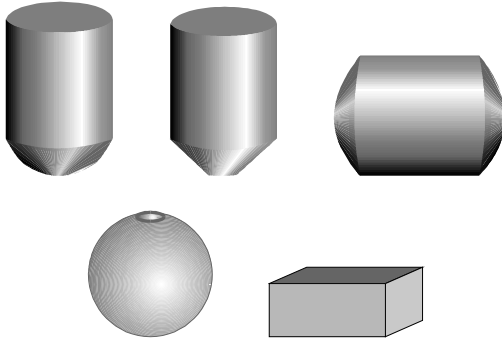

*With the dimensions of the tank entered, the software can calculate the volume or weight of the material for more than 10 tanks of different shapes

ENGINEERING/CALCULATION

- Metric or US and C° or F° programmable for the compact, to be specified when ordered for the two-part system

DISPLAY

- Can be assigned to any of the measured or calculated values as above
- Rounding of the value displayed can be selected

ANALOGUE OUTPUT

- Can be assigned to any of the measured or calculated values (independently from the assignment to the display with the two-part system; with the compact system the displayed value will be transmitted)
- Other programmable features:
 - Analogue output 0 ... 20 mA or 4 ... 20 mA (two-part system)
 - Normal or inverted mode (0/4 mA bottom, 20 mA top or 20 mA bottom, 0/4 mA top)
 - Failure indication modes: Hold, 3.6 mA, 22 mA

RELAY OUTPUTS

- Can be assigned to any of the measured or calculated values (independently from the assignment both to the display and the analogue output with the two-part system; with the Compact system the relay function can only be assigned to the value selected to display)
- Selection of over 30 and 4 different relay functions for the two-part and the standalone unit respectively
- Some of the relay functions
 - DIFFERENTIAL LEVEL SWITCHING (Hysteresis control)
 - WINDOW SWITCHING
 - HIGH/LOW FAILSAFE ALARM
 - FAILURE INDICATION
 - etc.
- Other user selectable features:
 - Energised or de-energised relay action
 - Adjustable time delay for relay action (two-part system)

32-POINT LINEARISATION CURVE

- Assignment of (up to 32) (displayed/transmitted) output values to the measured values (e.g. assignment of measured distance values to manually calculated volume values of bins with not pre-programmed shape)

FIXED TARGET SUPPRESSION

- Blocking out the interference of an echo from a fixed object (for the Compact units only)

AUTOMATIC SIGNAL PROCESSING FEATURES (QUEST+)

- Automatic floating average curve
- Automatic dead band control

ACCESS LOCK BY SECRET CODE

- Unauthorised access and programming can be prevented by a 4-digit secret code.

FULLY SELF DIAGNOSTIC SYSTEM WITH INDIVIDUAL ERROR MESSAGES

- Errors, depending on their nature, are assigned to different codes for customer information and action

DEVICE HISTORY

- Data relating to the device history, such as total operating hours, operation after last switch-on, number of switching actions for each relay, min. and max. temperatures registered, etc. can be read out

Service & test parameters

- Read-out data, reporting on operating conditions such as sensor gain, echo amplitude, noise level, etc. to facilitate the installation or troubleshooting of the system

RS485 INTERFACE

- RS485 with Nivelco protocol provides for remote control and data acquisition ability for the two-part system
- RS485 with MODBUS (under development) for the Compact unit

HART ABILITY

EchoTREK with HART and the *Eview* configuration software provides for remote programming and for obtaining primary measurement values (for the Compact unit only)

SIMULATION MODE

Outputs and devices connected to the level gauge can be checked by simulating static or continuous change of level with selectable parameters such as low and high level, as well as cycle time

DIGITAL SIGNAL INPUT (For Two-Part System only)

- This input can be used for various synchronising functions such as remote calibration by the output signal of a level switch

MEANS OF MEASUREMENT OPTIMIZATION

(described in detail in the Installation and Programming Manual)

- Blocking (close end, far end)
- Damping
- Angle of repose
- Target tracking speed
- Manual Echo selection
- Level elevation and descent rate
- Echo loss handling
- Echo map

Informational read out parameters

INSTALLATION

POSITION

For selection of the optimal sensor/transmitter location, various considerations should be made.

If the measured material is granular (material size > 5 mm) and the silo roof is dome shaped or conical, do not install the transmitter in the centre of the bin/silo. In general the transmitter can be installed at a radius of $r = (0.3 \dots 0.5) R$.

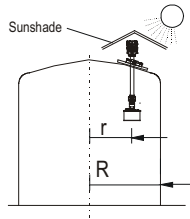

Avoid that the 5° conical beam angle of the transmitter contact the tank/silo wall. If the sensor/transmitter is mounted close to the wall, it should be tilted (See sensor alignment).

Install the unit as far away from the filling point(s) as possible.

PNEUMATIC FILLING

Mount the sensor at a place where the speed of the filled-in material reaches its lowest value as suggested on the diagram by the grey spot.

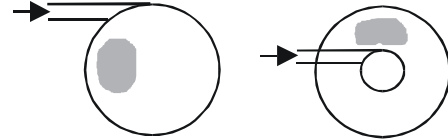

DUST

Dust in general reduces the distance the ultrasonic device can measure. This reduction is also dependent on the diameter of the tank/silo. The appropriate system and measuring range should be selected carefully.

MOUNTING

Due to angle repose of the free flowing solids the majority of the sensors / transmitters should be applied with an aiming device (SAA 102 that is part of the EchoTREK). The special split flange (see drawing) provide fast and easy way of mounting on silo / bin roof.

If the entire range of the aiming area is required, diameter and roof strength must be considered. Make use of dimensions in the table as a guideline for the design of the opening.

Diameter of the opening D	Thickness of the roof V
160 mm	110 mm
190 mm	150 mm
230 mm	200 mm
300 mm	280 mm
340 mm	300 mm

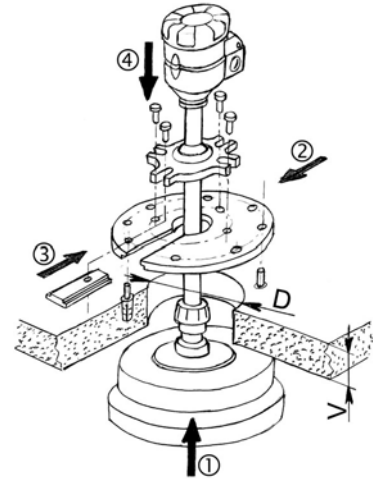

WIND

Intensive air movements in the vicinity of the ultrasonic cone are to be avoided. A strong wind or storm may "blow away" the ultrasound. If used outdoors, it is recommended to protect against strong winds by "shielding" the unit.

SUNSHADE

Make sure that the sensor or transmitter is protected against overheating by direct sunshine.

Sensor / transmitter can also be mounted on existing manhole covers or lids, or for instance, on a steel structure lowered into a larger (e.g. 0.5 x 0.5 m) opening on the roof.

SENSOR ALIGNMENT

To avoid problems caused by repose formation, in most cases aiming (tilting) of the device is required, which can easily be carried out with the SAA-102 Aiming Device of NIVELCO or with the aiming device incorporated in the EchoTREK. Aiming is best carried out, when the tank/silo is almost empty. In most cases, the sensor should be aimed towards the silo outlet. On applications where repose formation is not present or typically in tall and narrow silos (diameter: height = 1 : 5 or slimmer, e.g. $\varnothing 3 \times 18$ m) aiming is not always necessary; the sensor should face straight downwards.

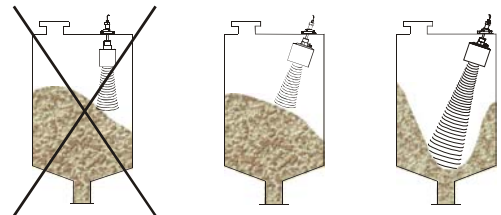

Electrical Connections of the Compact Transmitters

EchoTREK ST/SBD-3□□

- Wiring can be carried out by using one or two cables. Wires in group A must not be led in the same cable as wires in group B or C

Group A	Group B	Group C
Low voltage power supply	4 ... 20 mA	RS485 (shielded twisted pair)
Low voltage for the relay	SELV power supply	
	SELV power or logic signal for the relay	

- Devices must be grounded at the internal or external grounding screw terminal (use negative pole of the power supply for connecting to PLC grounding).
- Three-wire installation is also possible for the 24 V DC versions by connecting terminals 1 and 6. In this case the galvanic isolation is not provided.

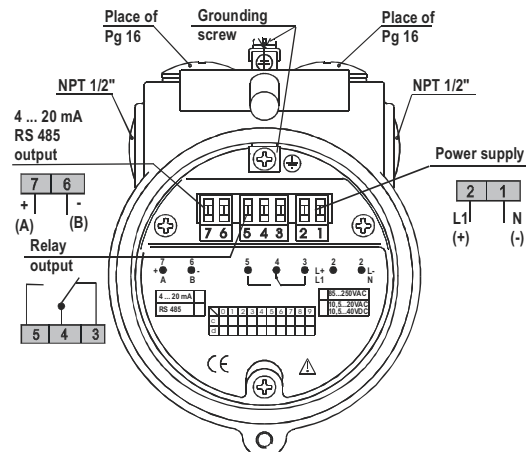

Electrical Connections of Two-Part Measurement Systems

SID-300 Sensors SM-300 Control Units

- To connect Sensors and Control Unit, use ordinary 4-wire shielded cables described in the "Technical Data Table"
- Signal cables must not be led in a common duct with high voltage lines
If signal cables of more than one sensor are led in common duct, make sure that they are individually shielded
- For safe grounding of the sensor, use the grounding screw terminal of the housing
- Connect additional program wire (MDP) of the SID-330/310/310-3 sensors as below:

Measuring range			MDP program wire
SID-330	SID-310	SID-310-3	
below 15 m	below 30 m	below 35 m	Leave unconnected
over 15 m	over 30 m	over 30 m	Connect to GND

Wiring between Sensor and Control Unit

SID-340/330/310 series Sensors

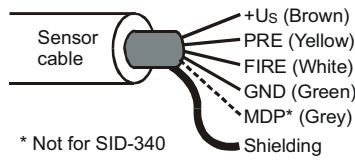

SID-310-H series Sensors

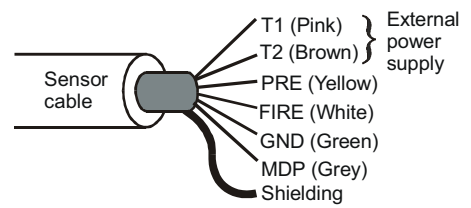

SMM, SMZ Remote control units

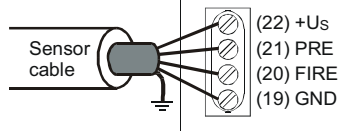

SMW, SMC, SMD, SMH Remote control units

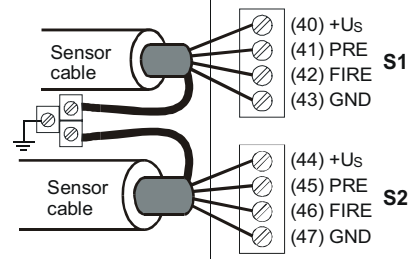

Wiring for the sensor signal cable extension

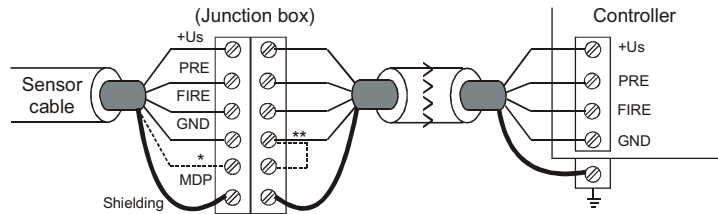

* Only in case of SID-330/310/310-H sensors

** Connection depending on measuring range, see table on the left.

- The SYNC input of the Control Units are TTL compatible
Active state: when the SYNC input is connected to the ground or the voltage on it is lower than 0.4V
Inactive state: when the SYNC input is left open/free or voltage on it is higher than 2.4 V ($U_{MAX} = 12 V$)

SMW, SMC, SMD, SMH AND SW-300 Wall Mounting Control Units

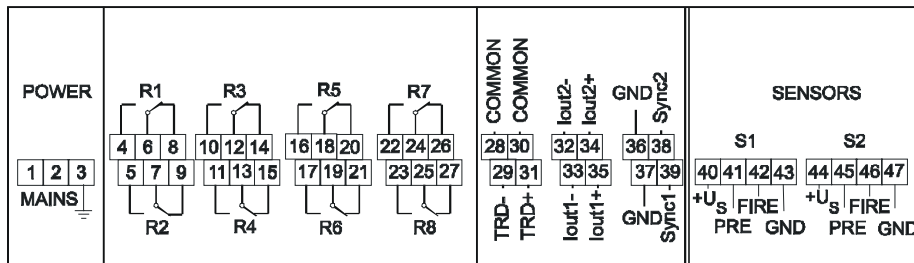

SMM, SMZ Panel Mounting Units

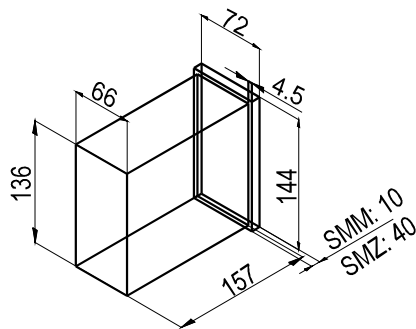
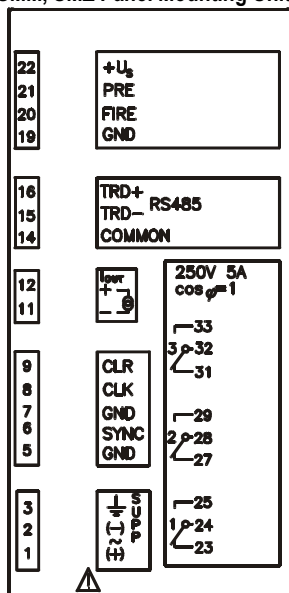

Cut-out dimensions: $68^{+0.7} \times 138^{+1.0}$

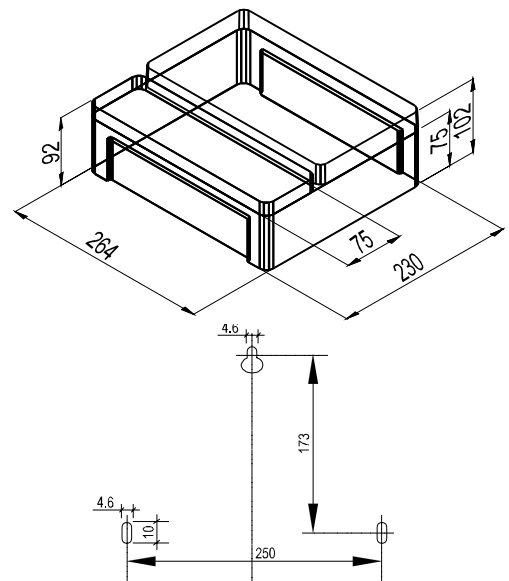

TECHNICAL DATA

ECHO TREK COMPACT TRANSMITTERS

GENERAL

Product name	EchoTREK STD/SBD-300 series
Product description	Compact type ultrasonic level transmitter
Transducer materials	Closed cell Polyurethane foam sensor face, Polypropylene sensor housing, Aluminium mounting base
Housing material	Powder paint coated Aluminium
Total beam angle	5°
Process temperature	-30°C ... +75°C
Ambient temperature	STD-300: -30°C ... +60°C ; SBD-300 : -25°C ... +60°C
Pressure (Absolute)	0.7 ... 1.1 bar (0.07 ... 0.11 MPa) ± 0.1 bar (0.01 MPa) difference between the closed and open area
Ingress protection	Sensor: IP65 (NEMA 5) Housing of the electronics: IP67 (NEMA 6)
Power supply / Consumption	Voltage version I: 120 ... 255 V DC/ 5.5 W and 85 ... 255 V AC (50/60Hz) / 6.8 VA Voltage version II: 10.5 ... 40 V DC/ 4.1 W and 10.5 ... 28 V AC (50/60Hz) / 4.6 VA
Accuracy*	± (0.2% of the measured distance plus +0.1% of the range)*
Resolution	10 mm
Outputs	Analogue: 4 ... 20 mA 600 Ohm, , overvoltage protection, galvanically isolated
	Relay: SPDT, 250 V AC, 3 A, AC1
	Display (SAP 100): with SBD-300 only, 6 digit LCD, icons and bargraph
	Digital: HART with Eview configuration software; RS485 with MODBUS
Electrical connections	2 x Pg 16 and 2 x 1/2" NPT Wire cross section (suggested): 0.5 ... 2.5mm ²
Electrical protection	Class I

*Under optimal conditions and stabilised sensor temperature.

SAP-100 PROGRAMMING MODULE

Field indication	6 digits, icons and bargraph, Custom LCD
Ambient temperature	-25°C ... + 60°C
Housing material	PBT fibre-glass reinforced plastic, flame-retardant (DuPont®)

Type	STD/SBD-34	STD/SBD-33	STD/SBD-31
Maximum measuring distance* [m / ft]	15 / 49	30 / 98	60 / 196
Minimum measuring distance* [m / ft]	0.6 / 2	0.6 / 2	1 / 3.33
Measuring frequency	30 kHz	30 kHz	15 kHz
Weight	7 kg		10 kg

*(from transducer face under optimal conditions)

SENSONAR SENSORS

GENERAL

Product name	SenSonar SID-300 series	
Product description	Dust – Ex sensor	Standard sensors
Sensor material	Paint-coated Aluminium housing with closed – cell Polystyrol foam facing	PP housing with closed - cell Polyurethane foam facing
Total beam angle	5°	
Process temperature	-30°C ... +75°C	
Pressure (Absolute)	0.7 to 1.1 bar (0.07 ... 0.11 MPa) ±0.1 bar (0.01 MPa) difference between the closed and open area	
Ingress protection	IP65	
Power supply	External 24 VAC, -15% to +10%, max. 5 VA (only for SID-310-3)	
Electrical connections	Direct cable outlet (standard 3 m; available up to 30 m)	
Cable between Sensor and Control Unit	SID-340/330/310: 4-wire shielded cable; wire cross section: 0.5 ... 2.5 mm ² ; max. 50 nF, max. 20 Ohm SID-310-3: 3-wire shielded cable; wire cross section: 0.5 ... 2.5 mm ² ; max. 50 nF, max. 20 Ohm and additional 2-wire cable for external power supply (LIYCY 3 x 0.75 mm ² and + 2 x 0.75 mm ²)	
Length of signal cable	Advised max. cable length: 300 m (with the cable suggested above);	
Electrical protection	Class III with surge protection	

Type	SID-340	SID-330	SID-310	SID-310-3**
Maximum measuring distance* [m / ft]	15 / 49	30 / 147	60 / 196	70 / 229
Minimum measuring distance* [m / ft]	0.6 / 2	0.6 / 2	1.2 / 4	1.5 / 5
Measuring frequency	40 kHz	30 kHz	15 kHz	15 kHz

* (from transducer face under optimal conditions) **with external power supply

NIVOSONAR CONTROL UNITS

Product name	Nivosonar SM-300 series	
Product description	Control unit for Two-Part Ultrasonic Level Metering System	
Mounting	SMM, SMZ: Panel Mounting SMW, SMC, SMD, SMH: Wall Mounting	
Measuring points	SMM, SMZ: 1 channel for 1 sensor SMW, SMC, SMD, SMH: 2 channels for up to 2 sensors	
Resolution	Up to 2 m: 1 mm; up to 5 m: 2 mm; up to 10 m: 5 mm; above 10 m: 10 mm	
Accuracy*	± (0.2% of the measured distance plus +0.1% of the range)*	
Ambient temperature	SMM, SMZ: 0°C ... +50°C SMW, SMC, SMD: -20°C ... +50°C SMH: -30°C ... +50°C	
Analogue output	Isolated; 0/4 ... 20 mA; max. 500 Ohm with surge protection	
Relay output	SPDT (NO/NC); 250 V AC, AC1, 5 A	
Electrical protection	Class II with surge protection	
Ingress protection	SMM: Front: IP 40; rear: IP 20 SMZ: Front: IP 54; rear: IP 20 SMW: IP 54 SMC, SMD, SMH: IP 65	
Supply voltage	230 or 110 or 24 V AC, 50/60 Hz; or 24 V DC, (specify when ordering)	
Power consumption	SMM, SMZ: max. 10 VA / 10 W SMW, SMC, SMD: max. 12 VA / 12 W SMH: max. 25 VA	

* Under optimal conditions and stabilised sensor temperature

APPROVALS

CE All NIVELCO's ultrasonic devices are designed and manufactured to conform to the following CE directives:

Directive 89/336 (for Electromagnetic Compatibility)



Directive 73/23 (93/68) (for Low Voltage Equipment)

The devices have been tested according to the following standards:

EN50081-1, EN50081-2, EN50082-1 EN50082-2, EN55022: 1987

IEC 801-2, IEC 801-3, IEC 801-4, CEI/IEC 61326-1, CEI/IEC 1000-4-5

Hazardous area approvals for SenSonar Sensors and EchoTREK transmitters:

- | | | | |
|------------------|--|-----------------------|------------------------------|
| • SID-300 series | Dust Ex Zone 10 (no ATEX) | No.: BVS 99.Y.8002 | Issued by: DMT (BVS) Germany |
| • SID-300 series | ATEX  II 1/2 D IP65 Zone 20 | BKI 03 ATEX 367X | Issued by: BKI Hungary |
| • STD-300 series | ATEX  II 1/2 D IP65 | No.:BVS 03 ATEX E 372 | Issued by: DMT (BVS) Germany |

Other approvals: See in our „Liquids” Data Sheet

APPLICATION EXAMPLES



Measurement of plastic pellets in 16 m silos



Measurement in 14 m silos containing cement, fly-ash and other ingredients for concrete manufacturing

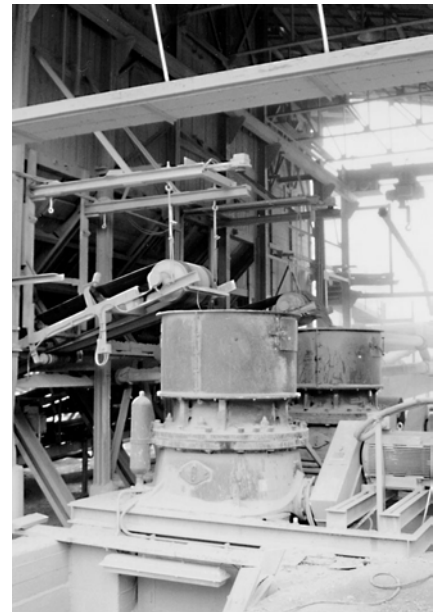

Level control of a stone crusher at a quarry



On the top of the silo containing plastic pellets



Measurement of sand, gravel etc. in open bins



Measurement of sugar powder in 22 m silos

DIMENSIONS

ECHOTREK COMPACT TRANSMITTERS

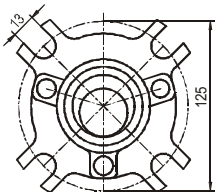
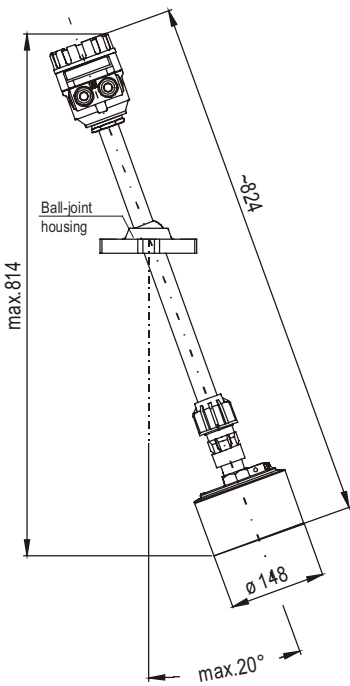
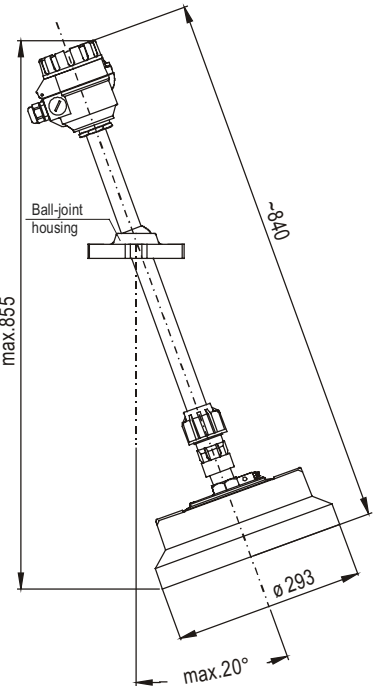
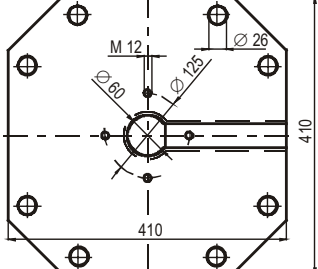
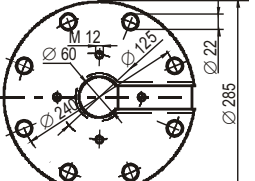
BALL-JOINT HOUSING (overhead view)	S□D-33J-□ S□D-34J-□	S□D-31J
		
SPLIT FLANGE		
 <p>SFA - 385</p>		
 <p>SFA - 355</p>		

SENSONAR SENSORS

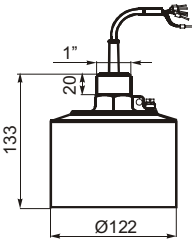
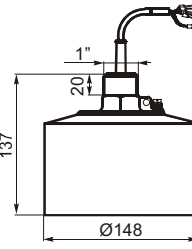
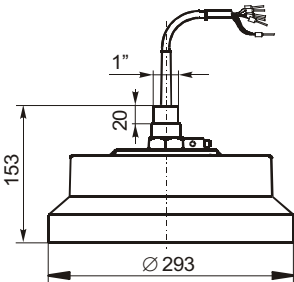
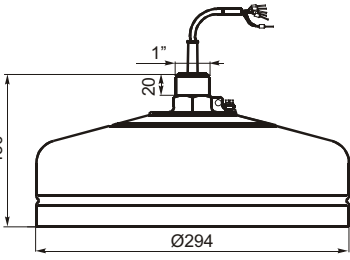
SenSonar SID-340	SenSonar SID-330	SenSonar SID-310	SenSonar SID-310 Ex
			

MOUNTING ACCESSORIES

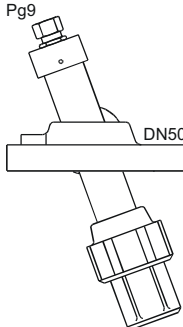
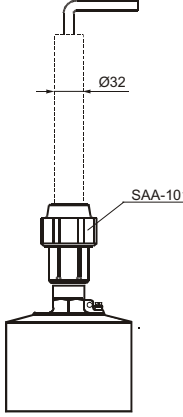
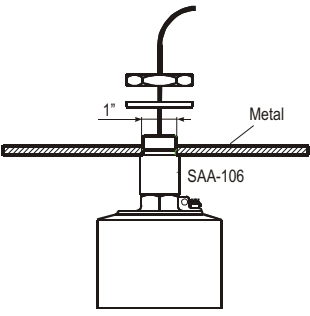
Aiming device (SAA-102)	Fast Connecting Gland	Damping Gland (SAA-106)
	 <p>For easy mounting to pipes</p>	 <p>Recommended when mounting sensors on a thin resonating plate</p>



sm30gs4a0608a

ORDER CODES

(Note: not all combinations of order numbers are possible)

ECHOTREK COMPACT TRANSMITTERS

EchoTREK S D - 3 J -

TYPE	CODE	RANGE	CODE	POWER SUPPLY / OUTPUT		CODE	
				STAND.	Ex		
Transmitter	T	60 m	1	Version I. 120 ... 255 V DC 85 ... 255 V AC			
Transmitter + Local Indicator	B	30 m	3	4 ... 20 mA + Relay	1	5	
		15 m	4	4 ... 20 mA + Relay + HART	3	7	
				RS 485 (MODBUS protocol) + Relay*	A	E	
				Version II. 10,5 ... 40 V DC 10,5 ... 28 V AC			
				4 ... 20 mA + Relay	2	6	
				4 ... 20 mA + Relay + HART	4	8	
				RS 485 (MODBUS protocol) + Relay*	B	F	

*under development

ECHOTREK SAP-100 Plug-in Programming Module

SENSORAR SENSORS (Two-part System)

S I D - 3 0 -

RANGE	CODE	EXTERN POWER SUPPLY / APPROVAL	CODE
60 m	1	None / none	0
30 m	3	None / Ex*	9
15 m	4	24 V AC / none	3

*Cenelec Dust Ex Zone 10 (not ATEX)

NIVOSONAR CONTROL UNITS (Two-Part System)

S M - 3 -

TYPE	CODE	CURRENT OUTPUT / Rs 485				RELAY OUTPUT	CODE	POWER SUPPLY / APPROVAL		CODE
		Single channel version		Dual channel version				STAND.	Ex	
Panel mount	M	None	1	None	5	0 Relay	0	230 V AC / Standard	1	
Panel mount, lockable cover	Z	1x 4 ... 20 mA	2	2 x 4 ... 20 mA	6	1 Relay	1	110 V AC / Standard	2	
Wall mount IP 54	W	RS 485	3	RS 485	7	2 Relays	2	24 V AC / Standard	3	
Wall mount IP 65 screw cover	C	1x 4 ... 20 mA + RS 485	4	2 x 4 ... 20 mA + RS 485	8	3 Relays	3	24 V DC / Standard	4	
Wall mount IP 65 lockable cover	D					4 Relays	4			
Wall mount IP 65 heated	H					5 Relays	5			
						6 Relays	6			
						7 Relays	7			
						8 Relays	8			

Technical specification may be changed without notice

NIVELCO PROCESS CONTROL CO.

H-1043 BUDAPEST, DUGONICS U. 11.

PHONE: (36-1) 369-7575 ♦ FAX: (36-1) 369-8585

E-mail: sales@nivelco.com http://www.nivelco.com